

# Comparing microbial and chemical kinetics for modelling soil organic carbon decomposition using the DecoChem v1.0 and DecoBio v1.0 models

Georgios Xenakis<sup>1,2</sup> and Mathew Williams<sup>1</sup>

<sup>1</sup>School of GeoSciences, University of Edinburgh, Crew Building, The King's Buildings, West Mains Road, Edinburgh, Midlothian EH9 3JN, UK

<sup>2</sup>Current address: Forest Research, Northern Research Station, Roslin, Midlothian EH25 9SY, UK

*Correspondence to:* Mathew Williams  
(Mat.Williams@ed.ac.uk)

**Abstract.** Soil organic matter is a vast store of carbon, with a critical role in the global carbon cycle. Despite its importance the dynamics of soil organic carbon decomposition, under the impact of climate change or changing litter inputs, are poorly understood. Current biogeochemical models usually lack microbial processes and thus miss an important feedback when considering the fate of carbon. Here we use a series of modelling experiments to evaluate two different model structures, one with a standard first order kinetic representation of soil decomposition (DecoChem v1.0, hereafter chemical model) and one with control of soil decomposition through microbial activity (DecoBio v1.0, hereafter biological model). The biological model includes cycling of organic matter into and out of microbial biomass, and simulates the decay rate as a functional of microbial activity. We tested two hypotheses. First, we hypothesised different responses in the two models to increased litter inputs and glucose additions. In the microbial model we hypothesised that this perturbation would prime microbial activity and reduce soil carbon stocks; in the chemical model we expected this perturbation to increase C stocks. In the biological model, responses to changed litter quantity were more rapid, but with the residence time of soil C altering such that soil C stocks were buffered. However, in the biological model there was a strong response to increased glucose additions (i.e., changes in litter quality), with significant losses to soil C stocks over time, driven by priming. Secondly, we hypothesised that warming will stimulate decomposition in the chemical model, and loss of C, but in the biological model soil C will be less sensitive to warming, due to complex microbial feedbacks. The numerical experiments supported this hypothesis, with the chemical model soil C residence times and steady state C stocks adjusting strongly with temperature changes, extending over decades. On the other hand, the biological model showed a rapid response to temperature that subsided after a few years, with total soil C stocks largely unchanged. The mi-

crobial model shows qualitative agreement with experimental warming studies, that found transient increases in soil respiration that decline within a few years. In conclusion, the biological model is largely buffered against bulk changes in litter inputs and climate, unlike the chemical model, while the biological model displays a strong priming response to additions of labile litter. Our result have therefore highlighted significantly different sensitivities between chemical and biological modelling approaches for soil decomposition.

## 1 Introduction

Soils are a major carbon store, of which approximately 50% can be found in the Northern Circumpolar Permafrost Region (NCPR), an area covering only 16% of the total global area (Tarnocai et al., 2009). Recent estimates found that total soil organic carbon (SOC) of NCPR is approximately 1672 Pg C with 88% of the carbon locked in perennially frozen soils and deposits. Their majority are deep soils with 1024 Pg C in the first 3 m (Tarnocai et al., 2009). In the Arctic region in particular, stocks in permafrost soil are significantly higher (1400-1850 Pg C) than vegetation stocks (60-70 Pg C) (Tarnocai et al., 2009). Soils are likely a sink of atmospheric CO<sub>2</sub> at a rate of approximately 0.4 Pg C yr<sup>-1</sup> (25% of the total ocean/land exchange), although this is uncertain (McGuire et al., 2009). Thus soils play an important role in the context of the global carbon cycles (McGuire et al., 2009).

Despite such importance, the sensitivity to climate change of SOC over different time scales, from hours to decades, is unknown (McGuire et al., 2009; Schmidt et al., 2011; Sanderson et al., 2011). Current state-of-the-art biogeochemical models have tended to represent SOC decomposition as a first order kinetic process, using various linked soil C pools of differing lability, with an exponential sensitivity to temperature, and a non-linear response to soil moisture (Fenner and Freeman, 2011; Ise et al., 2008; Jorgenson et al., 2010; Koven et al., 2011; Rogers et al., 2011; Wisser et al., 2011) for instance DNDC (Li et al., 1992, 1997), CENTURY (Parton et al., 1988; Metherell et al., 1993), RothC (Jenkinson and Rayner, 1977; Coleman et al., 1997) and ECOSSE (Smith et al., 2007, 2010). However, there are still a number of issues that are not presently addressed by these models, for instance the priming or recalcitrant soil C, which arise from recent field experiments and observations (Hartley et al., 2012) and which limit the ability of these models to quantify the short and long term responses of soils to climate change.

Schmidt et al. (2011) characterise a number of challenges for improving models of SOC dynamics. One of these is to replace the SOC pools of varying lability with a cycling of organic matter into and out of microbial biomass. Another recommendation is to model the decay rate as function of microbial activity. The focus of this paper is to compare a model based on these two recommendations (referred to here as the microbial or biological model) with the standard chemical model (as defined earlier), exploring steady state properties, and their sensitivity to litter inputs of different quality and

amount, and their temperature sensitivity.

In so doing we test two hypotheses: H1: Increased litter inputs and glucose addition will prime  
60 microbial activity and reduce SOC stocks in the biological model, but will increase SOC stocks in  
the chemical model. H2: Warming will stimulate decomposition in the chemical model, and loss  
of SOC, but in the biological model the SOC will be less sensitive to warming, due to complex  
interactions between SOC and the microbial pool.

The evaluation here is focused on model comparison, but is undertaken in an arctic context, us-  
65 ing meteorological data and carbon stocks measurements, for forcing and initial conditions, from  
a research site in northern Sweden (Sloan et al., 2013). Using biological and chemical SOC mod-  
els applied in an arctic context, our science objective is first to demonstrate steady state behaviour  
consistent with observed SOC and litter inputs. Then for each model we evaluate how much SOC  
will change by altering litter inputs (including changing litter quality) and how SOC is affected by  
70 temperature changes. This novel analysis provides critical information on model sensitivity vital for  
interpretation of any new regional or global simulations using models with microbial components  
for SOC decomposition.

## 2 Material and methods

To test our hypotheses and address the science objective, we developed and evaluated two sim-  
75 ple models representing two different concepts of SOC decomposition, DecoChem v1.0 (hereafter  
chemical model) and DecoBio v1.0 (hereafter biological model). The models have an hourly time-  
step, and so resolve diel cycles. However, there is no spatial detail, *i.e.* no representation of variations  
through the soil profile. In both cases litter inputs to the model were fixed and constant, for simplic-  
ity. The chemical model was based on the concept that decomposition is dependent on the chemistry  
80 of the soil organic matter and temperature (Li et al., 1992, 1997; Liski et al., 2005; Metherell et al.,  
1993; Parton et al., 1988; Smith et al., 2007, 2010). The biological model was based on the concept  
that decomposition is dependent on microbial biomass and activity (Panikov, 1995; Blagodatsky  
et al., 1998, 2010) and addresses the two challenges of Schmidt et al. (2011) outlined above. In the  
terminology of Wutzler and Reichstein (2008), the chemical model involves non-explicit representa-  
85 tion of decomposer biomass in SOC decomposition, with the assumption that each pool of SOC has  
its own decomposer community in consistent equilibrium. On the other hand, the biological model  
includes a non-linear representation of a single decomposer community that determines decomposi-  
tion of all SOC pools, with its microbial biomass and activity out of equilibrium with the substrate  
pools. The first stage of decomposition from fresh litter to SOC is simulated similarly in both mod-  
90 els. It is the second stage of decomposition, the turnover of SOC, that is simulated differently and  
compared here. For both models moisture effects on processes were not included, for simplicity.

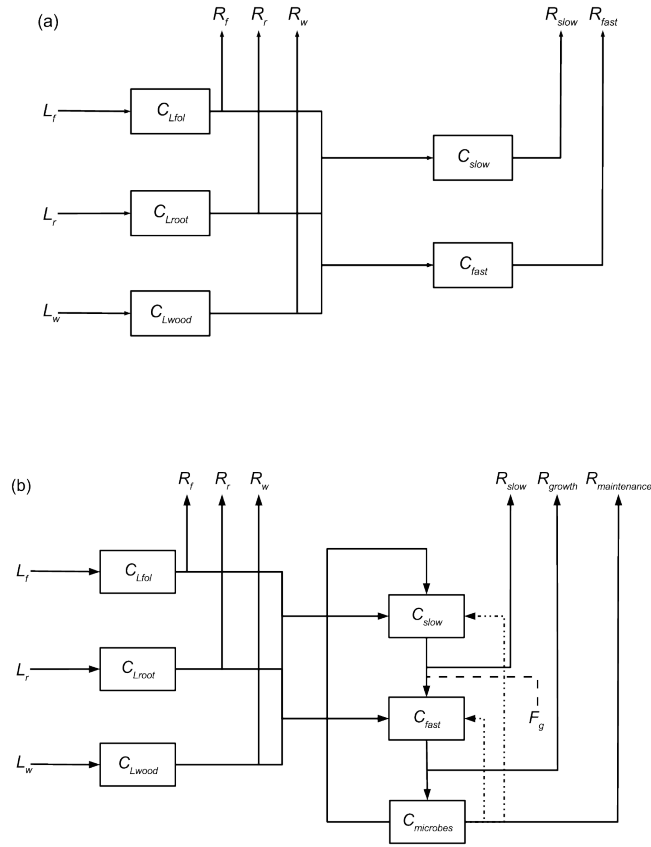

**Fig. 1.** Model diagram for a) the chemical and b) the biological model. Boxes represent pools, arrows with solid lines fluxes and arrows with dotted lines influence of a variable to a process.  $F_g$  ( $\text{gC m}^{-2} \text{h}^{-1}$ ) represents the input of glucose exudates for the litter quality experiment.

## 2.1 Modelling litter decomposition

In both model versions decomposition processes occurs in two stages. In the first stage litter from foliage, roots and wood is deposited to their respective litter pools, represented by three state variables (Figure 1). Each litter pool decomposes using a specific turnover rate ( $k_i, \text{h}^{-1}$ , Table 1, where  $i = fol, root, wood$  for foliage, root and wood) which is limited by a temperature response function (Equation 1) based on a  $Q_{10}$  value of 1.4 (Mahecha et al., 2010).

$$t_r = e^{\ln Q_{10} \cdot \frac{T}{10}} \quad (1)$$

A constant hourly input of litterfall was set based on field measurements, different for each of

**Table 1.** State variables, parameters and fluxes of both the biological and chemical model.

Symbols	Description	Units	Value		Reference
			<i>Chemical</i>	<i>Biological</i>	
<i>Parameters</i>					
$k_{fol}$	Decomposition rate for foliage litter pool	$h^{-1}$	0.0001142	0.0001142	Calibrated
$k_{root}$	Decomposition rate for root litter pool	$h^{-1}$	0.0000571	0.0000571	Calibrated
$k_{wood}$	Decomposition rate for wood litter pool	$h^{-1}$	0.0000228	0.0000228	Calibrated
$k_{slow}$	Decomposition rate for slow soil pool	$h^{-1}$	0.0000011	0.0189945	Schädel et al. (2013); Calibrated
$k_{fast}$	Decomposition rate for fast soil pool	$h^{-1}$	0.0000114	-	Calibrated
$k_{mu}$	Second order rate constant for microbial C uptake	$m^2 g C^{-1} h^{-1}$	-	0.0047044	Blagodatsky et al. (2010)
$f_{lignin}$	Fraction of lignin	-	0.376	0.376	Calibrated
$e_{d1}$	Efficiency of decomposition of the first stage decomposition	-	0.5	0.5	Calibrated
$e_{d2}$	Efficiency of decomposition of microbial decomposition	-	-	0.02	Blagodatsky et al. (2010)
$e_u$	Efficiency of substrate uptake by microbes	-	-	0.62	Blagodatsky et al. (2010); Calibrated
$m_{dx}$	Maximum microbial death rate	$h^{-1}$	0.01	0.01	Blagodatsky et al. (2011); Calibrated
$m_{di}$	Inhibition constant for microbial death rate	-	0.213	0.213	Blagodatsky et al. (2011)
$m_c$	Maintenance coefficient	$h^{-1}$	-	0.0208	Blagodatsky et al. (2010)
$i_c$	Inhibition constant for C-dependent microbial activity	$gC m^{-2}$	-	154.09	Blagodatsky et al. (2010)
$Q_{10}$	$Q_{10}$ temperature response	-	1.4	1.4	Mahecha et al. (2010)
<i>State variables</i>					
$C_{Lf}$	Foliage litter pool	$gC m^{-2}$	14.06	14.06	Sloan et al. (2013)
$C_{Lr}$	Root litter pool	$gC m^{-2}$	180.04	180.04	Sloan et al. (2013)
$C_{Lw}$	Wood litter pool	$gC m^{-2}$	131.78	131.78	Sloan et al. (2013)
$C_{slow}$	Slow soil carbon pool	$gC m^{-2}$	1243.21	3500	?Blagodatsky et al. (2010)
$C_{fast}$	Fast soil carbon pool	$gC m^{-2}$	0.58	0.58	Blagodatsky et al. (2010)
$C_g$	Soil carbon with added glucose	$gC m^{-2} h^{-1}$	-	0.000571	-
$C_{microbes}$	Microbial biomass	$gC m^{-2}$	-	35.00	Blagodatsky et al. (2010)
$m_d$	Microbial death rate	$h^{-1}$	-	-	-
$m_{act}$	Microbial activity	-	-	-	-
$m_{act_i}$	Initial microbial activity	-	-	0.0585	Blagodatsky et al. (2010)
$d_{m_{act}}/dt$	Differential of microbial activity	$h^{-1}$	-	-	-
<i>Fluxes</i>					
$L_f$	Litterfall of foliage, root and wood	$h^{-1}$	0.00642	0.00642	Sloan et al. (2013)
$L_r$	Litter carbon pool for foliage, root and wood	$h^{-1}$	0.00287	0.00287	Sloan et al. (2013)
$L_w$	Litter carbon pool for wood	$h^{-1}$	0.00391	0.00391	Sloan et al. (2013)
$R_s$	Total soil respiration	$gC m^{-2} d^{-1}$	-	-	-
$R_d$	Respiration from soil decomposition	$gC m^{-2} d^{-1}$	-	-	-
$R_l$	Respiration from litter decomposition	$gC m^{-2} d^{-1}$	-	-	-
sum $R_s$	Sum of total soil respiration over a year	$gC m^{-2} yr^{-1}$	-	-	-
sum $L_i$	Sum of litter inputs over a year	$gC m^{-2} yr^{-1}$	-	-	-

100 the three structural pools ( $L_i$ ,  $\text{h}^{-1}$ , Table 1, Sloan et al., 2013). The change of each litter pool ( $C_{L_i}$ ,  $\text{gC m}^{-2}$ ) per hourly time step is determined from litter input and output of the first stage of decomposition (Equation 2), a simple first order turnover.

$$\frac{dC_{L_i}}{dt} = L_i - t_r \cdot k_i \cdot C_{L_i} \quad (2)$$

where  $i = \text{fol}, \text{root}, \text{wood}$  for foliage, root and wood respectively.

105 Part of the quantity decomposed during the first stage of decomposition moves to the next stage (either biological or chemical model) while the rest is emitted as respiration ( $R_l$ ,  $\text{gC m}^{-2} \text{d}^{-1}$ , Equation 3). How much of the decomposed carbon enters the second phase depends on the first stage efficiency of decomposition ( $e_{d_1}$ , Table 1) and temperature ( $t_r$ ).

$$R_l = (1 - e_{d_1}) \cdot t_r \cdot k_i \cdot C_{L_i} \quad (3)$$

110 where  $i = \text{fol}, \text{root}, \text{wood}$  for foliage, root and wood respectively. Differences in structure between the two models were introduced for the second stage of decomposition to illustrate the difference between the purely chemical decomposition versus that affected by microbial activity. Although the concept of splitting the total amount of carbon into two pools exists for both models, the major difference is in the structure of carbon flow (Figure 1).

### 115 2.1.1 DecoChem: A chemical model of SOC decomposition

The chemical model has two state variables, the  $C_{slow}$  and  $C_{fast}$  SOC pools. Carbon from  $C_{fast}$  flows into  $C_{slow}$  after decomposition (Figure 1a) with a portion lost as respiration based on  $e_{d_1}$ . Decomposition of  $C_{fast}$  (Equation 4) is proportional to its size with a constant decomposition rate ( $k_{fast}$ ,  $\text{h}^{-1}$ ) modified by temperature. Carbon inputs from the first stage of decomposition were  
 120 kept similar to the biological model, with carbon being split into the two pools based on  $f_{lignin}$  and with the lignin based carbon compounds deposited into  $C_{slow}$ .

$$\frac{dC_{fast}}{dt} = (1 - f_{lignin}) \cdot e_{d_1} \cdot t_r \cdot k_i \cdot C_{L_i} - t_r \cdot k_{fast} \cdot C_{fast} \quad (4)$$

$C_{slow}$  is further decomposed with a constant rate ( $k_{slow}$ ,  $\text{h}^{-1}$ ) and limited by  $t_r$ , with the decomposed carbon removed from the pool as respiration (Equation 5 and Figure 1a).

$$125 \frac{dC_{slow}}{dt} = f_{lignin} \cdot e_d \cdot t_r \cdot k_i \cdot C_{L_i} + e_d \cdot t_r \cdot k_{fast} \cdot C_{fast} - t_r \cdot k_{slow} \cdot C_{slow} \quad (5)$$

Respiration from soil decomposition then is calculated as the sum of respiration during decomposition of  $C_{fast}$  and  $C_{slow}$  (Equation 6).

$$R_d = (1 - e_d) \cdot t_r \cdot k_{fast} \cdot C_{fast} + t_r \cdot k_{slow} \cdot C_{slow} \quad (6)$$

Total soil heterotrophic respiration is calculated as the sum of respiration from litter and respiration from soil decomposition (Equation 13).

### 2.1.2 DecoBio: A biological model of SOC decomposition

In the biological model, there are four further state variables; a slow (recalcitrant) SOC pool, a fast (labile) SOC pool, a microbial pool and a microbial activity (Fig1b). We have adopted and adapted the concept of microbial activity as a dynamic variable, used to represent the impact of microbial biomass on decomposition processes (Blagodatsky et al., 1998, 2010). The activity depends on the size of fast SOC pool (Equation 7), which means microbes become more active when there is more labile carbon to consume. We also introduced a temperature limitation through  $t_r$  arguing that the microbial community becomes more active under warmer conditions. This parameter introduces an indirect effect of temperature for all soil processes associated with microbial activity.

$$\frac{dm_{act}}{dt} = t_r \cdot k_{mu} \cdot C_{fast} \cdot \left( \frac{C_{fast}}{C_{fast} + i_c} - m_{act} \right) \quad (7)$$

The dynamics of the activity is a modified Michaelis-Menten response inhibited by the actual size of the parameter and in our study was allowed to vary between 0 and 1.

Carbon from the first stage of decomposition is deposited to both slow ( $C_{slow}$ ,  $\text{gC m}^{-2}$ ) and fast ( $C_{fast}$ ,  $\text{gC m}^{-2}$ ) pool (Figure 1b) based on the litter fraction of lignin ( $f_{lignin}$ , Table 1). Lignin based carbon is allocated to  $C_{slow}$  (Equation 8) whereas the rest is allocated to  $C_{fast}$  (Equation 10).

$$\frac{dC_{slow}}{dt} = f_{lignin} \cdot e_d \cdot t_r \cdot k_i \cdot C_{L_i} + t_r \cdot m_d \cdot C_{microbes} - k_{slow} \cdot m_{act} \cdot C_{microbes} \quad (8)$$

where  $i = fol, root, wood$  for foliage, root and wood respectively. Decomposition of  $C_{slow}$  depends on the size of microbial biomass ( $C_{microbes}$ ,  $\text{gC m}^{-2}$ ), its microbial activity  $m_{act}$  and a constant rate ( $k_{slow}$ ,  $\text{h}^{-1}$ ) of decomposition. A further input of carbon is deposited by microbial death, which is proportional to  $C_{microbes}$  and a microbial death parameter ( $m_d$ ,  $\text{h}^{-1}$ , Equation 8).  $m_d$  is determined by a Michaelis-Menten function (Equation 9) adapted by Blagodatsky et al. (2011) using a maximum rate ( $m_{d_x}$ ,  $\text{h}^{-1}$ ) and an inhibition constant ( $m_{d_i}$ )

$$m_d = \frac{m_{d_x}}{1 + m_{d_i}} \quad (9)$$

A portion of the carbon flowing out of the  $C_{slow}$  pool enters  $C_{fast}$  (Figure 1b) based on a microbial efficiency of decomposition ( $e_{d_2}$ , Table 1 and Equation 10) while the rest is emitted as part of the total soil respiration.

$$\frac{dC_{fast}}{dt} = (1 - f_{lignin}) \cdot e_{d_2} \cdot t_r \cdot k_i \cdot C_{L_i} + e_{d_2} \cdot t_r \cdot k_{slow} \cdot m_{act} \cdot C_{microbes} - k_{mc} \cdot C_{fast} \cdot m_{act} \cdot C_{microbes} \quad (10)$$

where  $i = fol, root, wood$  for foliage, root and wood respectively. Together with carbon deposited to  $C_{fast}$  from the first stage decomposition, carbon is also allocated from  $C_{slow}$  (Figure 1b) after accounting for respiratory losses. Carbon is removed from the  $C_{fast}$  pool by microbial uptake which depends on the size of  $C_{microbes}$  and a constant rate for microbial carbon uptake ( $k_{mu}$ ,  $m^2 g C^{-1} h^{-1}$ ) and microbial activity ( $m_{act}$ , Equation 10).

Microbial biomass ( $C_{microbes}$ ,  $g C m^{-2}$  Equation 11) grows each time step by consuming carbon from  $C_{fast}$  and is reduced by microbial death and by maintenance respiration (Equation 12).

$$\frac{dC_{microbes}}{dt} = e_u \cdot k_{mu} \cdot C_{fast} \cdot m_{act} \cdot C_{microbes} - m_c \cdot m_{act} \cdot C_{microbes} - m_d \cdot t_r \cdot C_{microbes} \quad (11)$$

Maintenance respiration is calculated as a portion of  $C_{microbes}$  with a constant rate ( $m_c$ ,  $h^{-1}$ ) limited by  $m_{act}$ . Respiration from soil decomposition ( $R_d$ ,  $g C m^{-2} d^{-1}$ ) is the sum of respiration during decomposition of  $C_{slow}$ , respiration during growth and maintenance of  $C_{microbes}$  (Equation 12 and Figure 1b)

$$R_d = (1 - e_{d_2}) \cdot k_{slow} \cdot t_r \cdot C_{microbes} + (1 - e_u) \cdot k_{mc} \cdot C_{fast} \cdot m_{act} \cdot C_{microbes} + m_c \cdot m_{act} \cdot C_{microbes} \quad (12)$$

Similar to the chemical model, total soil heterotrophic respiration is then calculated as the sum of soil decomposition and decomposition of the litter pools (Equation 13).

$$R_s = R_l + R_d \quad (13)$$

## 2.2 Parameterization and steady state

Before running the numerical experiments the steady state conditions for both models were explored. First, any temperature variation effect on decomposition was initially switched off in both models (*i.e.*, the parameter adjusting the temperature rate was held constant at 1). The decomposition rates for the chemical model and biological models were tuned manually and were allowed to spin up for 1000 years. The process was repeated until pools were in steady state, with inputs equal to outputs. Then the mean residence time for each pool was calculated (MRT, yrs) as the ratio between the sum of fluxes out of the pool to the size of pool (Equation 14).

$$MRT = \frac{\sum \text{flux}_{out}}{C_{pool}} \quad (14)$$



**Table 2.** Summary of the size of all carbon pools of the chemical and biological models including foliage litter ( $C_{L_f}$ ,  $\text{gC m}^{-2}$ ), root litter ( $C_{L_r}$ ,  $\text{gC m}^{-2}$ ), wood litter ( $C_{L_w}$ ,  $\text{gC m}^{-2}$ ), fast soil carbon ( $C_{fast}$ ,  $\text{gC m}^{-2}$ ), slow soil carbon ( $C_{slow}$ ,  $\text{gC m}^{-2}$ ) and microbial biomass ( $C_{microbes}$ ,  $\text{gC m}^{-2}$ ) at the end of the 1000 year spin up run, their respective Mean Residence Time (MRT, yrs) and the sum over a single year of total soil respiration (sum  $R_s$ ,  $\text{gC m}^{-2} \text{ yr}^{-1}$ ) and total litter input (sum  $L_i$ ,  $\text{gC m}^{-2} \text{ yr}^{-1}$ ).

	With no climate			With climate		
	Pool size	MRT	Total fluxes	Pool size	MRT	Total fluxes
<i>Chemical</i>						
$C_{L_f}$	56.23	1.00		53.33	0.95	
$C_{L_r}$	68.65	2.00		64.96	1.90	
$C_{L_w}$	125.67	5.00		118.84	4.74	
$C_{fast}$	359.68	10.00		341.63	9.47	
$C_{slow}$	3865.87	100.00		3756.86	94.76	
sum $R_s$			114.80			115.86
sum $L_i$			116.26			116.23
<i>Biological</i>						
$C_{L_f}$	56.23	1.00		53.33	0.95	
$C_{L_r}$	68.65	2.00		64.96	1.90	
$C_{L_w}$	125.81	5.00		118.84	4.74	
$C_{fast}$	5.08	0.14		5.02	0.14	
$C_{slow}$	3485.60	119.43		3485.26	119.63	
$C_{microbes}$	5.50	0.24		5.55	0.24	
sum $R_s$			116.09			115.97
sum $L_i$			116.28			116.28

Decomposition rates and efficiency of decomposition of the first stage were calibrated to produce a MRT of 1, 2 and 5 years for  $C_{L_f}$ ,  $C_{L_r}$  and  $C_{L_w}$  respectively. For the chemical model parameters were calibrated to produce a MRT of 10 and 100 years for  $C_{fast}$  and  $C_{slow}$  respectively. These MRTs are reasonable given incubation data (Schädel et al., 2013). For the biological model, parameters associated with the microbial activity, efficiency of microbial decomposition, microbial death and maintenance coefficients were extracted from literature (Blagodatsky et al., 1998, 2010, 2011). Decomposition rate of the slow SOC pool ( $k_{slow}$ ,  $\text{h}^{-1}$ ) and  $f_{lignin}$  were calibrated separately for each model to ensure that the pool reached a reasonable steady state. In a second phase of calibration, we included diurnal and seasonal variation in temperature, using observations, and both models were allowed to spin up for another 1000 yr to reach steady state. Results were summarised and MRTs for each pool of each model were calculated. We then calculated the sum over a single year for total soil respiration (sum  $R_s$ ,  $\text{gC m}^{-2} \text{ d}^{-1}$ ) and total litter input (sum  $L_i$ ,  $\text{gC m}^{-2} \text{ d}^{-1}$ ) for both models to confirm steady state conditions.

### 2.3 Parameter sensitivity analysis

We performed a sensitivity analysis following the methodology described in Xenakis et al. (2008). The sensitivity was calculated for 6 outputs of the biological model (4 state variables,  $R_d$  and  $R_s$ ) to the change of its 17 parameters, and 4 model outputs of the chemical model (2 state variables,  $R_d$  and  $R_s$ ) to the change of 11 parameters. One parameter at a time was increased and decreased by 25% and the model run for 1000 years from a steady state. The relative sensitivity of each model output was then calculated as the relative change of the output to the relative change of the parameter (Equation 15).

$$\lambda = \frac{p}{X_0} \frac{X_+ - X_-}{2\delta p} \quad (15)$$

where  $X_0$  is the model output with nominal parameters and  $X_+$  and  $X_-$  is the model output when the parameter was increased and decreased respectively.  $p$  is the parameter value and  $\delta p$  is the change of the parameter. The index  $\lambda$  demonstrates the relation between the output and parameter as first derivative of their relationship, and shows the strength of the sensitivity of a model output to the parameter as well as the direction of the impact it will have. For example a  $\lambda$  of zero indicates no sensitivity of the output to the parameter whereas a value close or greater than 1 indicates high sensitivity. A negative value of  $\lambda$  indicates than an increase of the parameter decreased the output while a positive value indicates outputs increased with parameters.

### 2.4 Numerical experiments

We explored our hypotheses by running three numerical experiments using both models to allow an evaluation of the different sensitivities of the models to litter inputs and temperature forcing. For testing H1 we performed a litter change experiment, and a carbon (glucose) addition experiment, and for H2 a temperature sensitivity experiment. All experiments were performed after ensuring models had reached a steady state. Carbon stocks ( $\text{gC m}^{-2}$ ) for all pools including total soil carbon ( $C_{total}$ ,  $\text{gCm}^{-2}$ ),  $C_{fast}$ ,  $C_{slow}$  and  $C_{microbes}$  were plotted and MRT (yrs) calculated for all scenarios in each experiment. The percentage change (%) of total soil respiration between the nominal and experiment scenarios was also calculated and plotted.

#### 2.4.1 Experiment 1 and 2: Litter input and glucose addition

Two related numerical experiments on litter additions were undertaken, with varying litter lability, for both models. In the first experiment we increased and decreased total litter input (*i.e.*, similar increase for each of foliage, root and wood litter) by 25% of the nominal value and ran both models for 1000 years for all three scenarios (nominal, increased and decreased root litter). This experiment tested sensitivity to a bulk change in plant litter production. In the second experiment we tested specifically for the effect of glucose exudation (*i.e.*, inputs increased to  $C_{fast}$ , a change in litter

quality and quantity), to test for the effects of priming. Starting from a steady state, we added 5  
230  $\text{gC m}^{-2} \text{yr}^{-1}$  (Blagodatsky et al., 2010), applied directly to  $C_{fast}$  every time-step *i.e.* hour.

### 2.4.2 Experiment 3: Temperature sensitivity

Both models were run for 1000 years from a steady state comparing two temperature scenarios  
(warming and cooling). Temperature data were obtained from the ABACUS project (Street et al.,  
2013) for a dwarf birch site (*Betula nana* L.) located in Abisko, northern Sweden. Warming and  
235 cooling scenarios were developed by increasing and decreasing the measured hourly temperature by  
 $2^\circ\text{C}$  respectively.

## 3 Results

### 3.1 Model steady state conditions

The steady state for both models was tested by comparing the sum of total litter input and the sum of  
240 total soil respiration, with temperature variation switched on and off. We found that values closely  
matched after 1000 years (Table 2), with differences varying between 1.2% and 0.3% which we  
deemed an acceptable steady state. The calibration of the first stage of decomposition generated  
MRTs for the three litter pools of 1, 2 and 5 years for foliage, root and wood respectively (Table 2).  
In the biological model turnover of  $C_{slow}$  was slower compared to the chemical model, with a 20%  
245 larger MRT. However, in the biological model  $C_{fast}$  MRT was nearly 2 orders of magnitude smaller  
than in the chemical model (Table 2) indicating a more rapid turnover.

For the biological model microbial biomass had a MRT 71% larger than  $C_{fast}$ . Including vari-  
able temperature reduced the MRT of the biological model by 5% for  $C_{Lf}$ ,  $C_{Lr}$  and  $C_{Lw}$ , by 1%  
for  $C_{fast}$  and increased MRT for  $C_{slow}$  by 0.17%. For the chemical model including variable tem-  
250 perature decreased MRT for all litter pools by 5% (Table 2).

Slow organic carbon stocks at steady state were 10% larger in the chemical model (Table 2).  
Fast organic carbon stocks were approximately 71 times smaller in the biological model. Together  
with the fast turnover (small MRT) these differences in stocks highlight the conceptual difference  
between the two models. In the case of the biological model,  $C_{fast}$  represents a very short residence  
255 pool with carbon moving rapidly into the microbial pool. In the case of the chemical model,  $C_{fast}$   
represent the standard approach in soil carbon modelling, which is a pathway for carbon moving  
from litter to recalcitrant humus, with turnover faster than those of the old pool.

### 3.2 Sensitivity analysis

Some important differences in the sensitivity of both  $C_{slow}$  and  $C_{fast}$  were observed between the  
260 two models (Figure 2). In the biological model,  $C_{slow}$  had very low sensitivity to the three litter  
input ( $< 0.1$ ) in contrast to the chemical model where  $C_{slow}$  showed sensitivity to litter from foliage

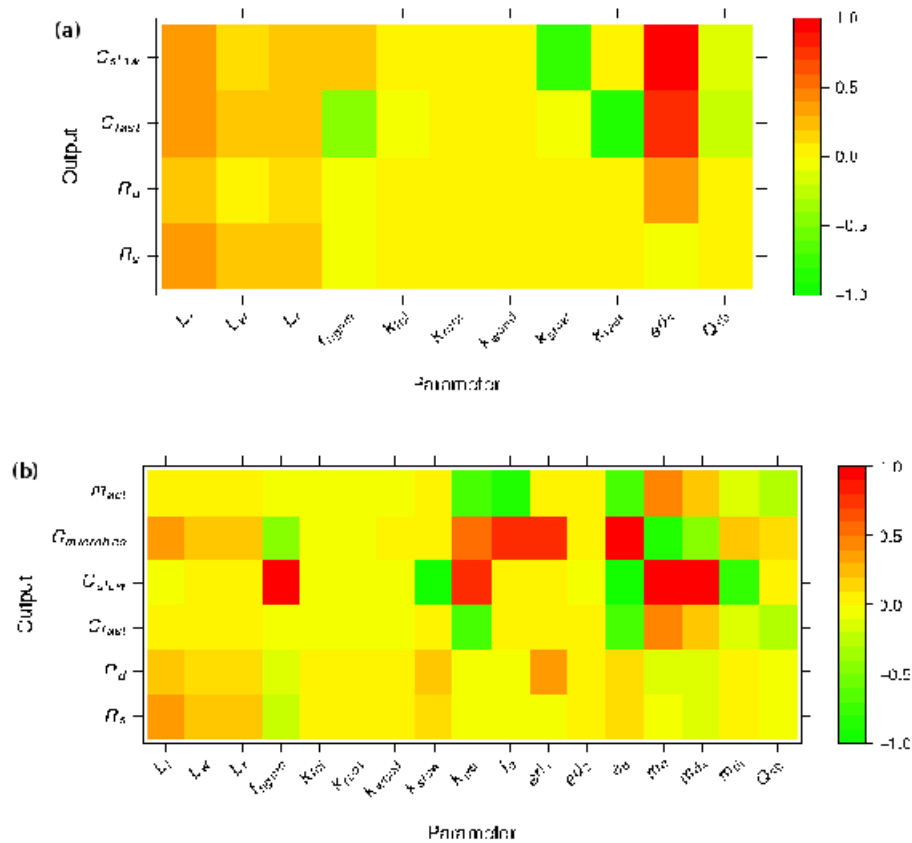
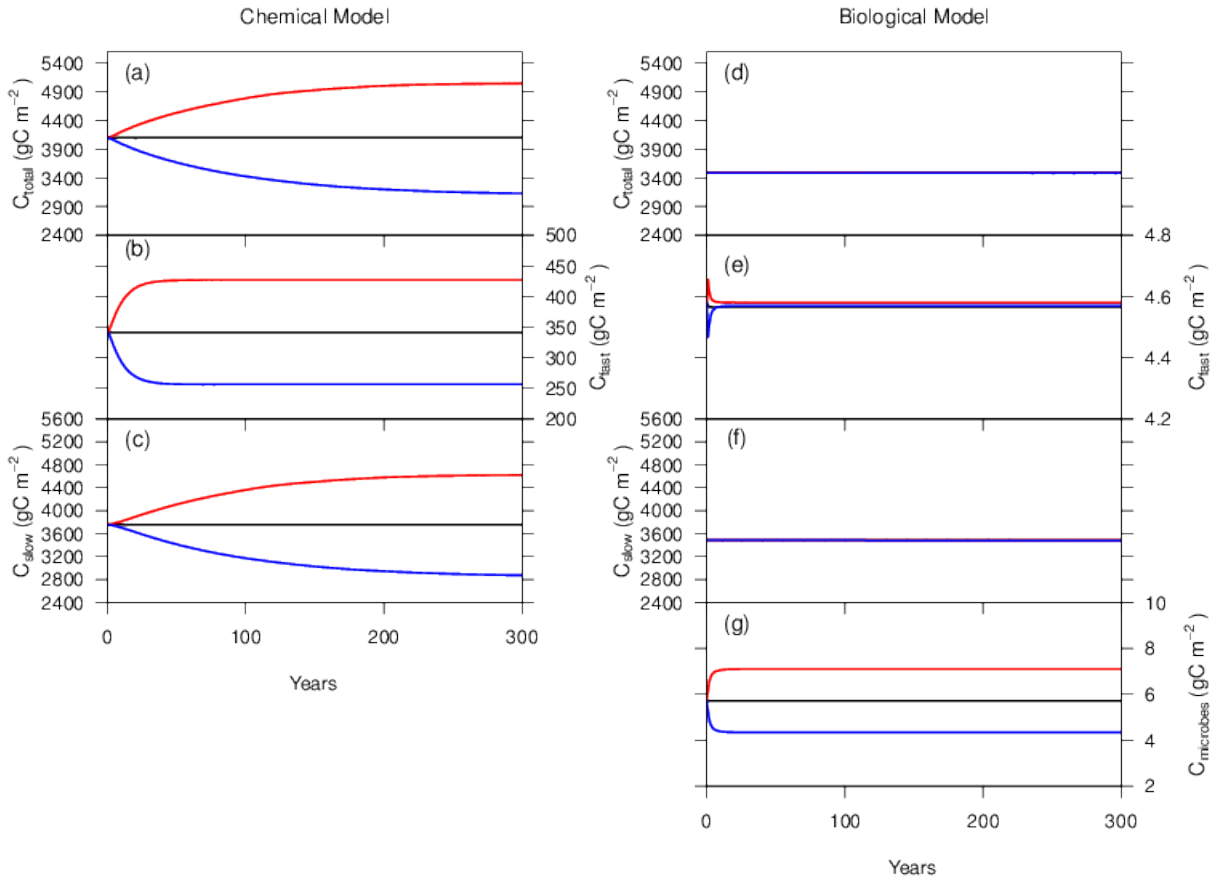

**Fig. 2.** Sensitivity of the two model to their respective parameters. Outputs tested were all three soil carbon pools including  $C_{fast}$  and  $C_{slow}$  for a) the chemical model and fast ( $C_{fast}$ ,  $\text{gC m}^{-2}$ ), slow ( $C_{slow}$ ,  $\text{gC m}^{-2}$ ) and microbial pool ( $C_{microbes}$ ,  $\text{gC m}^{-2}$ ) for b) the biological model. Also the sensitivity of three respiration fluxes were tested including total soil respiration ( $R_s$ ,  $\text{gC m}^{-2} \text{d}^{-1}$ ), litter respiration ( $R_l$ ,  $\text{gC m}^{-2} \text{d}^{-1}$ ) and respiration from soil decomposition ( $R_d$ ,  $\text{gC m}^{-2} \text{d}^{-1}$ ) for both models. Model sensitivity was calculated using the method by Xenakis et al. (2008). Values close or greater to -1 and 1 show high negative and positive sensitivity respectively. For all symbols explanation see Table 1.

with  $\lambda$  of 0.40, from roots 0.26, and from wood 0.19. Litter inputs had also very low impact ( $< 0.1$ ) on  $C_{fast}$  in the biological model while in the chemical model  $C_{fast}$  was found to be sensitive to inputs of foliage litter, with  $\lambda$  of 0.48, of roots ( $\lambda = 0.29$ ) and wood ( $\lambda = 0.21$ ).

265  $C_{fast}$  in the biological model was most sensitive to  $m_c$ ,  $k_{mu}$ ,  $e_u$  and  $Q_{10}$ , parameters related to maintenance respiration, the rate and efficiency of microbial carbon uptake and temperature effect on decomposition processes.  $C_{fast}$  in the chemical model was most sensitive to  $e_{d1}$ ,  $k_{fast}$  and  $f_{lignin}$ , parameters related to the efficiency of litter decomposition, the fraction of lignin in litter and the decomposition rate.

270 The sensitivity of  $C_{slow}$  in the chemical model was linked to the parameters  $k_{slow}$ ,  $e_{d1}$  and  $f_{lignin}$



**Fig. 3.** Soil carbon stocks of the chemical and biological models for the litter quantity experiments. a) Is the total soil carbon ( $C_{total}$ ,  $\text{gC m}^{-2}$ ), b) fast pool ( $C_{fast}$ ,  $\text{gC m}^{-2}$ ), c) slow pool ( $C_{slow}$ ,  $\text{gC m}^{-2}$ ) of the chemical model, d) is the total soil carbon ( $C_{total}$ ,  $\text{gC m}^{-2}$ ), e) fast pool ( $C_{fast}$ ,  $\text{gC m}^{-2}$ ), f) slow pool ( $C_{slow}$ ,  $\text{gC m}^{-2}$ ) and g) microbial biomass ( $C_{microbes}$ ,  $\text{gC m}^{-2}$ ) of the biological model. Black line shows the nominal run, red line the increased litter and blue the decrease litter scenario. Only the first 300 years of the simulation are shown.

which determine the rate of decomposition, the fraction of lignin which is gives the fraction of decomposed carbon that is directly deposited to the pool and the efficiency of litter decomposition.  $C_{slow}$  in the biological model was sensitive to  $k_{slow}$ ,  $f_{lignin}$ ,  $e_u$ ,  $m_{d_i}$ ,  $k_{m_u}$ ,  $m_c$  and  $m_{d_x}$ , which control processes relating to the efficiency of carbon uptake by microbes, maintenance respiration and microbial death.

Sensitivity of  $R_s$  and  $R_d$  to litter were the same for the two models.  $R_s$  was most sensitive to foliage ( $\lambda = 0.49$ ) having slightly lower sensitivity to root litter ( $\lambda = 0.30$ ) with similar pattern for the chemical model. Respiration due to soil decomposition was most sensitive to foliage litter input with  $\lambda$  of 0.24, followed by root litter ( $\lambda = 0.15$ ) and wood litter input ( $\lambda = 0.11$ ). There was a

280 similar pattern for the chemical model.

$C_{microbes}$  also showed high sensitivity to  $m_{d_x}$ ,  $f_{lignin}$ ,  $k_{mu}$ ,  $m_{d_i}$ ,  $e_{d_1}$  and  $m_c$ , parameters related to microbial death, efficiency of decomposition and rate of carbon uptake by the microbial biomass. The sensitivity analysis of the biological model showed a high sensitivity of the microbial biomass to foliage litter input ( $\lambda = 0.47$ ) and a much lower sensitivity to roots ( $\lambda = 0.29$ ) and wood ( $\lambda = 0.21$ )  
285 respectively. This sensitivity of  $C_{microbes}$  to foliage, root and wood litter inputs can be explained by the rate of decomposition of each litter pool. The highest sensitivity is related to the litter with the higher decomposition rate (foliage) and vice versa (wood).

Comparing the sensitivities of the two models, we found that the introduction of a microbial pool buffered the sensitivity of other carbon pools to the amount of input litter. It did however introduce  
290 extra sensitivity to parameters related to microbial dynamics. Total soil respiration at steady state was found to be relatively insensitive to parameters related to microbial activity. Respiration of soil decomposition was found to be sensitive to the efficiency of decomposition of the first stage for both the biological ( $\lambda = 0.5$ ) and chemical model ( $\lambda = 0.45$ ).

### 3.3 Litter quantity manipulation

#### 295 3.3.1 Chemical model

In the chemical model, the response of  $C_{fast}$  was more significant in magnitude than the biological case, but slower reaching a maximum change in  $C_{fast}$  stocks of  $\pm 25\%$  by year 75 for both litter scenarios (Figure 3b). Unlike the biological model, MRT remained unchanged at approximately 9 years (Table 3). The response of  $C_{slow}$  was found to have a maximum change of 25% after 1000  
300 years for both scenarios. Again, unlike the biological model, the MRT of  $C_{slow}$  was unchanged. Total SOC response was similar to that of  $C_{slow}$ . Total soil respiration approached a steady state towards the end of the 1000 years of simulation, with a final change of 25% for both litter scenarios (Figure 4a).

#### 3.3.2 Biological model

305  $C_{microbes}$  responded rapidly to changes in litter quantity, reaching steady values within 30 years, increasing by 19% for the 25% rise in litter and declining by 39% for the 25% decline in litter (Figure 3g). The change in MRT at steady state was small for both litter scenarios (0.72% and 1.15% respectively) remaining at 0.25 years (Table 3).

$C_{fast}$  also responded rapidly to changes in litter, but the magnitude of change was much lower  
310 than for  $C_{microbes}$ . When litter was increased by 25% the pool reached its maximum response with the first 2 years, initially increasing by 2% and later returning close to its original steady value after ~14 years. When litter was reduced by 25% there was a similar, although negative response for the first 2 years but with a decline of 2.2%. The pool returned to the original steady state after 24 years

**Table 3.** Summary of all three experiment and nominal runs for both the biological and chemical models. For each carbon pool, including foliage litter ( $C_{L_f}$ ,  $\text{gC m}^{-2}$ ), root litter ( $C_{L_r}$ ,  $\text{gC m}^{-2}$ ), wood litter ( $C_{L_w}$ ,  $\text{gC m}^{-2}$ ), fast soil carbon ( $C_{fast}$ ,  $\text{gC m}^{-2}$ ), slow soil carbon ( $C_{slow}$ ,  $\text{gC m}^{-2}$ ) and microbial biomass ( $C_{microbes}$ ,  $\text{gC m}^{-2}$ ), the size of the pool at the end of the 1000 year run, the Mean Residence Time (MRT, yrs) and the percentage change (%) of MRT between the nominal and experiment run are given. The table also presents the sum of fluxes over a single year's simulation of total soil respiration (sum  $R_s$ ,  $\text{gC m}^{-2} \text{ yr}^{-1}$ ) and total litter input (sum  $L_i$ ,  $\text{gC m}^{-2} \text{ yr}^{-1}$ ).

	Litter quantity												Temperature change												
	Nominal						Litter quality						Increase						Decrease						
	Pool size	MRT	Total fluxes	% change	Pool size	MRT	Total fluxes	% change	Pool size	MRT	Total fluxes	% change	Pool size	MRT	Total fluxes	% change	Pool size	MRT	Total fluxes	% change	Pool size	MRT	Total fluxes	% change	
<i>Chemical</i>																									
$C_{L_f}$	52.45	0.93	65.56	0.93	39.34	0.93	0.01	52.45	0.93	49.02	0.87	-6.54	56.13	1.00	7.01										
$C_{L_r}$	64.30	1.87	80.38	1.87	48.23	1.87	0.01	64.30	1.87	60.09	1.75	-6.56	68.81	2.00	7.02										
$C_{L_w}$	118.30	4.70	147.87	4.70	88.73	4.70	0.01	118.30	4.70	110.57	4.39	-6.53	126.57	5.03	6.99										
$C_{fast}$	341.46	9.44	426.89	9.44	256.12	9.44	-0.01	388.71	18.87	319.21	8.82	99.94	365.22	10.09	6.97										
$C_{slow}$	3761.44	94.42	4646.28	94.42	2847.83	94.42		3996.53	94.42	3525.39	88.28	-6.51	4015.52	101.00	6.96										
sum $R_s$	115.91		144.30		87.21					120.90					115.83										
sum $L_i$	115.96		144.95		86.97					120.97					115.96										
<i>Biological</i>																									
$C_{L_f}$	52.45	0.93	65.56	0.93	39.34	0.93		52.45	0.93	49.02	0.87	-6.55	56.13	1.00	7.01										
$C_{L_r}$	64.30	1.87	80.38	1.87	48.23	1.87		64.30	1.87	60.09	1.75	-6.56	68.81	2.00	7.02										
$C_{L_w}$	118.30	4.70	147.88	4.70	88.73	4.70		118.30	4.70	110.57	4.39	-6.53	126.57	5.03	6.99										
$C_{fast}$	4.57	0.12	4.58	0.10	-19.75	0.17		4.64	0.11	4.56	0.12	-10.83	4.57	0.12	0.02										
$C_{slow}$	3485.10	119.28	3474.95	95.15	-20.23	138.14		3465.49	13.39	3483.14	119.21	-88.78	3486.65	119.34	0.05										
$C_{microbes}$	5.72	0.25	7.09	0.25	-0.72	0.25		6.45	0.25	5.71	0.25	-0.93	5.72	0.25	0.06										
sum $R_s$	115.97		144.96		86.98					124.01					115.97										
sum $L_i$	115.96		144.95		86.97					120.97					115.96										

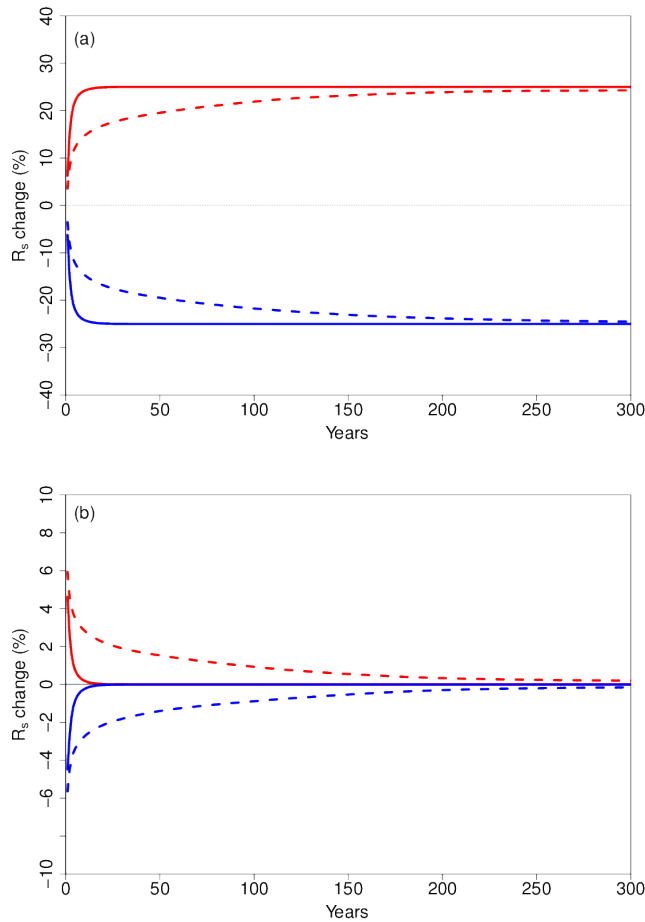

**Fig. 4.** The percentage change (%) of total soil respiration between the nominal and increased litter (red lines) and the nominal and decreased litter (blue lines) for a) the litter quantity manipulation experiment and b) the temperature manipulation experiment. Solid lines are for the biological and dashed lines for the chemical model. Only the first 300 years of the simulation are shown.

(Figure 3e).

315 Because of the small change to the  $C_{fast}$  carbon stock with a change in throughput, its MRT declined by 20% with 25% litter increase and increased by 33% for 25% litter decrease (Figure 3f).  $C_{slow}$  on the other hand responded very slowly to changes in litter. There was only 0.03% change in stocks after 10 years for both scenarios. No steady state was reached after 1000 years, with a 0.56% increase over that period for the decrease scenario and 0.29% decrease for the increase scenario.

320 Increasing litter inputs reduced MRT of  $C_{slow}$  by 20% after 1000 years (Table 3) associated with an insignificant change in C stocks. A decrease in litter slowed turnover of  $C_{slow}$  by 33% after 1000 years. The initial response of the microbial activity (data not shown) after the first year increased by 1.9% for increased litter and decreased by 2.2% for the decreased litter scenario. After 15 years the response of microbial activity to litter fell to 0.42% for the increased litter scenario and to very



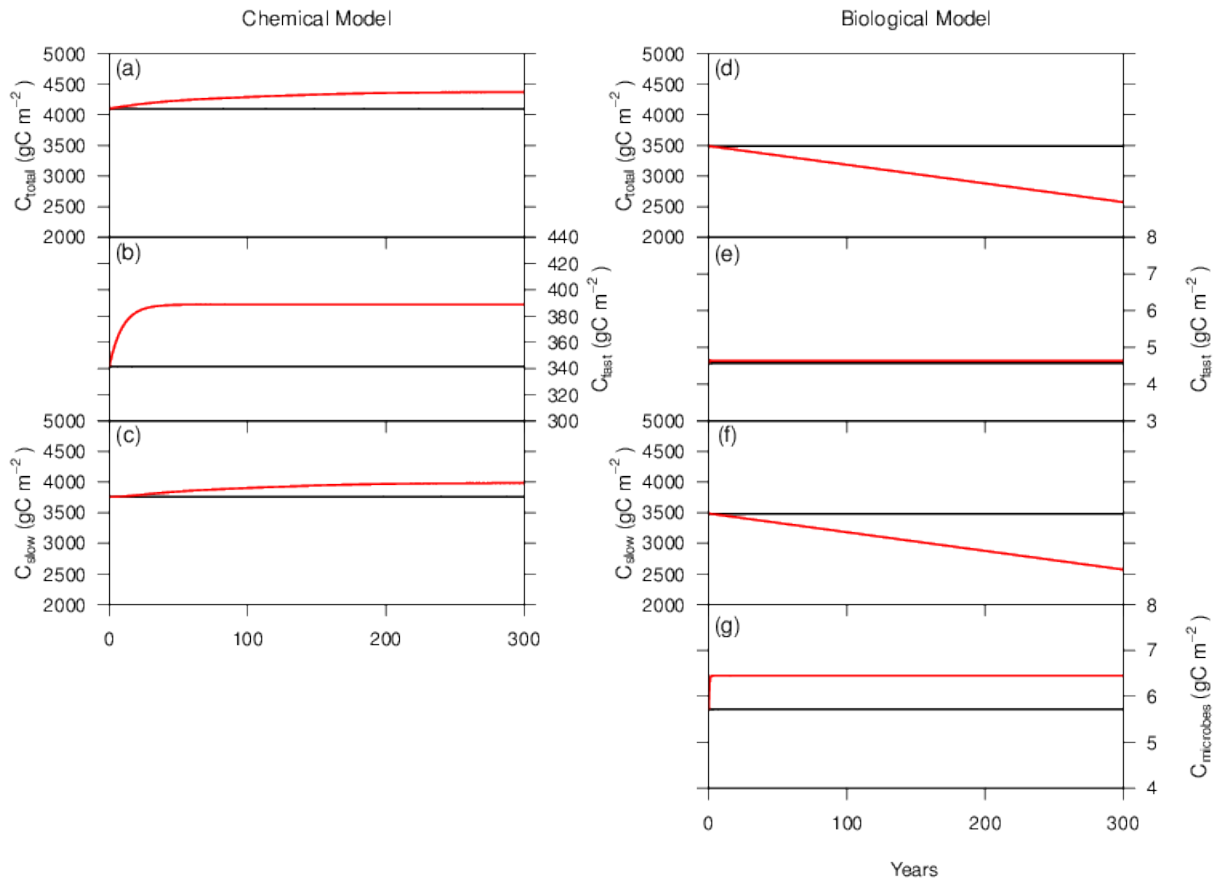

**Fig. 5.** Soil carbon stocks of the chemical and biological models for the litter quality experiments. a) Is the total soil carbon ( $C_{total}$ ,  $\text{gC m}^{-2}$ ), b) fast pool ( $C_{fast}$ ,  $\text{gC m}^{-2}$ ), c) slow pool ( $C_{slow}$ ,  $\text{gC m}^{-2}$ ) d) microbial biomass ( $C_{microbes}$ ,  $\text{gC m}^{-2}$ ) of the biological model, e) is the total soil carbon for the chemical ( $C_{total}$ ,  $\text{gC m}^{-2}$ ), f) fast pool ( $C_{fast}$ ,  $\text{gC m}^{-2}$ ) and g) slow pool ( $C_{slow}$ ,  $\text{gC m}^{-2}$ ) of the chemical model. Black lines show runs with no addition and red lines with addition of glucose exudates. Only the first 300 years of the simulation are shown.

325 insignificant change (0.01%) for the decreased scenario, until the end of the simulation.  $C_{total}$  response was similar to that of  $C_{slow}$  because of the relative size difference between the slow and fast pool. Total soil respiration was found to have a sharp change from its nominal condition reaching its maximum change of 25% within 35 years for both litter scenarios (Figure 4a).

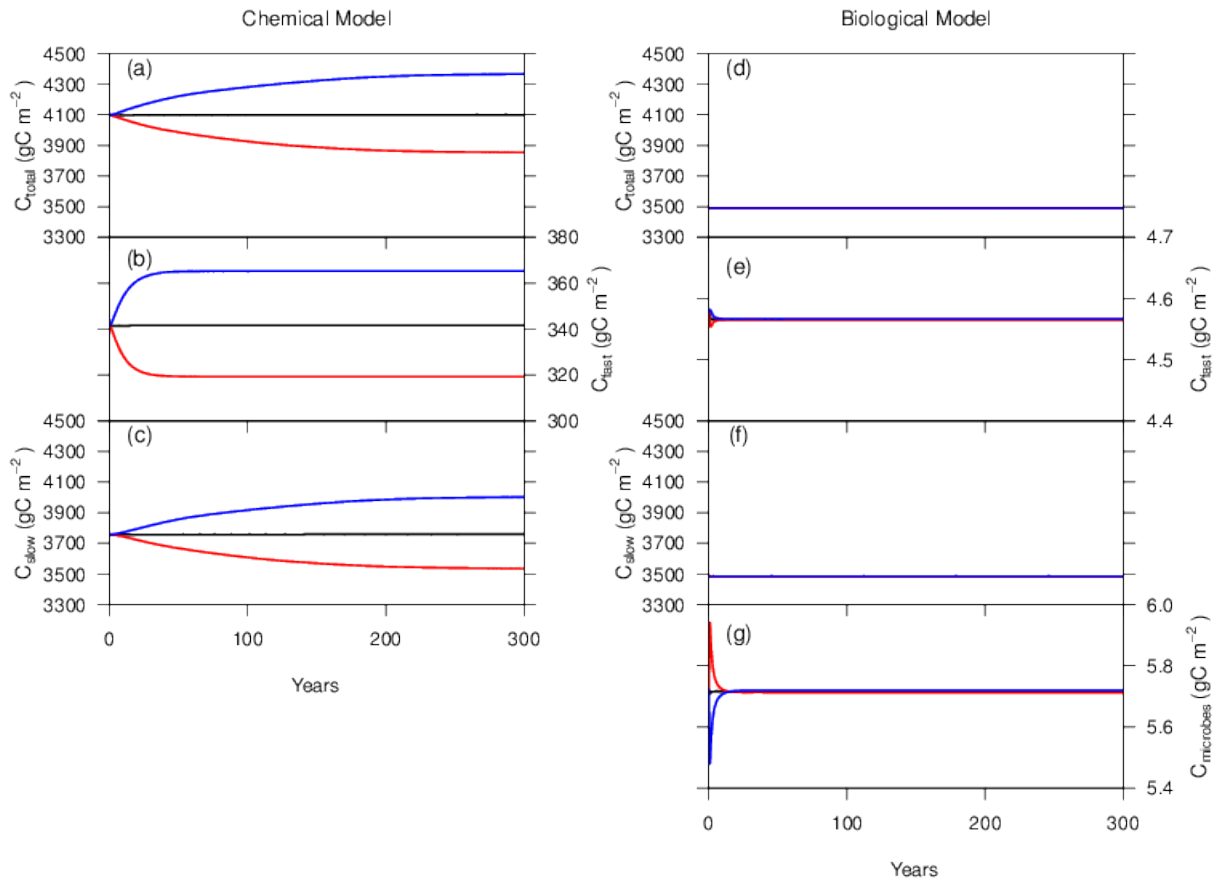

**Fig. 6.** Soil carbon stocks of the chemical and biological models for the temperature change experiments. a) Is the total soil carbon ( $C_{total}$ ,  $\text{gC m}^{-2}$ ), b) fast pool ( $C_{fast}$ ,  $\text{gC m}^{-2}$ ), c) slow pool ( $C_{slow}$ ,  $\text{gC m}^{-2}$ ) d) microbial biomass ( $C_{microbes}$ ,  $\text{gC m}^{-2}$ ) of the biological model, e) is the total soil carbon for the chemical ( $C_{total}$ ,  $\text{gC m}^{-2}$ ), f) fast pool ( $C_{fast}$ ,  $\text{gC m}^{-2}$ ) and g) slow pool ( $C_{slow}$ ,  $\text{gC m}^{-2}$ ) of the chemical model. Black line shows the nominal run, red line the warming and blue the cooling scenario. Only the first 300 years of the simulation are shown.

### 3.4 Litter quality manipulation

#### 330 3.4.1 Chemical model

The extra  $5 \text{ gC m}^{-2} \text{ yr}^{-1}$  added to  $C_{fast}$  caused a gradual increase of the pool in the chemical model, with a new steady state 14% larger achieved by year 84 (Figure 5b). This increased stock was linked to a slower turnover rate, with the MRT doubling (Table 3).  $C_{slow}$  increased even more slowly, rising by 6% by the end of the 1000 years simulation with MRT remaining unchanged. The overall response was an increase in total carbon stored in the soil pools (Figure 5a).

335

### 3.4.2 Biological model

Changing the quality of litter by adding  $5 \text{ gC m}^{-2} \text{ yr}^{-1}$  extra glucose exudation directly to the fast soil organic carbon pool (*i.e.*, priming) had a great impact on the size and MRT of  $C_{slow}$  (Figure 5f). By the end of the 1000 years simulation  $C_{slow}$  was still declining, with a total reduction of 87%.  
340  $C_{slow}$  MRT declined by 89% (Table 3).  $C_{microbes}$  increased by 12% within 1 year of the start of the simulation and remained at this new steady state for the rest of the simulation (Figure 5g). However, the change on  $C_{microbes}$  MRT was very small (0.93%).  $C_{fast}$  although receiving directly the added glucose exudate only increased slightly by 2% in the first year and then settled to a steady state change of 1%. Its MRT however was reduced by 11%. Microbial activity responded by an initial  
345 increase of 2% dropping to a steady state change of 1%. The overall response was a continuing and major decline over the 1000 years experiment in total C stocks in soil (Figure 5d).

## 3.5 Temperature manipulation

### 3.5.1 Chemical model

Response of  $C_{fast}$  in the chemical model was significantly different from that of the biological.  
350 Warming reduced the pool by 7% within 65 years while cooling caused an increase in carbon by 7% again within the same period (Figure 6b), in both cases reaching new steady states. MRT was reduced by 6% by warming and increased by 7% by cooling (Table 3).  $C_{slow}$  responded to the change with a decrease in stocks by the end of the 1000 year simulation of 6% with warming and an increase by 7% with cooling. MRT of  $C_{slow}$  was reduced by 6% with warming and increased by  
355 7% cooling. The overall response of C stocks (Figure 6a) was 6% for the warming and 7% for the cooling scenario over the 1000 year period. Total soil respiration increased by 6% for the warming and decreased by 6% for the cooling scenario but it only return to its original value towards the end of the simulation, at ~1000 years (Figure 4b).

### 3.5.2 Biological model

360  $C_{microbes}$  responded to temperature change with an initial increased of 4% in the warming and decreased of 4% in the cooling scenario. But within 3 years stocks returned close to their initial values in both cases (Figure 6g). The MRT of  $C_{microbes}$  remained unchanged at 0.25 years at their new steady states, for both the increased and decreased temperature numerical experiments. After an initial 0.30% response to warming/cooling,  $C_{fast}$  then returned to its original steady state value  
365 within a few years (Figure 6e). The change in MRT of  $C_{fast}$  with both scenarios was insignificant, 0.05% and 0.06% for warming and cooling respectively (Figure 6g).

$C_{slow}$  responded very slowly to the change, and had not reached a steady state after 1000 years. Both scenarios caused a decreased in C stocks over the 1000 years period reaching a change of 0.06% for the warming and 0.04% for the cooling scenario. Microbial activity was decreased by

370 0.3% the first year for the warming scenario and increased by the same percentage for the cooling  
scenario, but returned to their initial values by year 10. The overall response of C stocks (Figure 6d)  
by the end of the 1000 year simulation was a decrease by 0.06% for the warming and an increase by  
0.04% for the cooling scenario. Total respiration increased the first year by 5% for the warming and  
375 value within 20 years.  
decreased by 4.5% for the cooling scenario (Figure 4b) and then returned to the original steady state

## 4 Discussion

The numerical experiments highlight the key difference between the models. For changes in litter  
inputs, MRT adjusts in the biological model to buffer changes to  $C_{slow}$ . However, MRT is unchanged  
in the chemical model leading to significant adjustments in  $C_{total}$ . For changes in temperature, MRT  
380 is insensitive in the biological model, again buffering changes in  $C_{total}$ ; in the chemical model MRT  
responds, leading to significant adjustments to  $C_{total}$ . Only for changes in litter quality, *i.e.*, priming,  
does the biological model have greater sensitivity in  $C_{slow}$  than in the chemical model.

### 4.1 H1. Litter inputs and glucose additions will prime microbial activity and reduce SOC stocks in the biological model, but will increase SOC stocks in the chemical model

385 Our results (Figure 3) provided some support for this hypothesis. Increasing total litter input into the  
ecosystem primed microbial activity in the biological model by increasing microbial biomass and  
thus reducing old carbon ( $C_{slow}$ ) MRTs.

The biological model reached its new steady state more rapidly than the chemical model in re-  
sponse to changes in litter quality. Thus, litter changes in the biological model led to more rapid  
390 responses in respiration than in a typical chemically based system (Figure 4). The change in respi-  
ration between the two models after they reached their new steady state was not very different, but  
the timing difference were significant (Figure 4a), so, there are important differences between long  
term and short term effects. The ecological implication is that a biological model will have a more  
rapid response of soil respiration in the early years of the added carbon, with more immediate effect.  
395 In a more realistic case with litter added as pulses rather than continuously, this might mean higher  
peaks in respiration fluxes with the beginning of senescence.

Schmidt et al. (2011) proposed that fresh root inputs will prime microbial activity. The sensitivity  
analysis (Figure 2) indicated that an increase in root litter would increase microbial biomass and thus  
provide larger microbial community which when active will prime old organic carbon. However, we  
400 found that fresh foliage litter will have an even larger impact on microbial biomass probably due  
to the high sensitivity of the microbes to the lignin fraction (Figure 2b). Our observed microbial  
priming from root and foliage litter can also explain the hypothesis suggested by Hartley et al.  
(2012) that arctic plant growth has a positive priming on soil carbon reducing old organic carbon,

and also can support their observations of changing soil carbon stocks at the transition from low  
405 Arctic tundra vegetation to birch forest. When birch starts to substitute tundra, we can hypothesize  
that a larger input of labile carbon arises, because of higher production and a shift to deciduous,  
thinner leaves, which primes microbial activity.

For the biological model, the large decline in  $C_{slow}$  in response to glucose addition over 1000  
years, and the lack of a new steady state developing, (Figure 5) is noteworthy. The sustained increase  
410 in microbial biomass resulting from priming with glucose allows a continual and constant increased  
decomposition rate of  $C_{slow}$  (Figure 5f). The biological model is missing any feedback processes  
that might result in a new steady state, for instance physical protection of some fraction of  $C_{slow}$ .  
Also, increased decomposition, leading to mineralization of N, is likely to increase woody fraction  
of litterfall as plant production rises. This lignification of litter should adjust decomposition over  
415 time. Further model development are required to evaluate these feedbacks.

Adding extra labile carbon (glucose) directly into the biological system increased microbial car-  
bon consumption from  $C_{fast}$ , increased  $C_{microbes}$ , primed microbial activity and increased the de-  
composition of  $C_{slow}$  (Figure 5). Microbial priming is a tested concept in short term incubation  
studies (Blagodatsky et al., 1998, 2010). Although evidence of the impact of microbial activity  
420 and priming on decomposition has started to appear in the literature (Turetsky et al., 2008; Allison  
et al., 2010; Hartley et al., 2012; Frey et al., 2013), very little is known about the longer term impact  
on carbon stocks. The importance of considering alternatives to the typical chemical based model  
is demonstrated by the impact the microbial community dynamics has on old organic carbon after  
the addition of extra labile carbon. Our biological model showed that a small increase of 13% to  
425  $C_{microbes}$  reduced the turnover time of the old carbon pool by almost 106 years and significantly  
reduced total soil carbon stocks by 87% over 1000 years.

Introducing microbial dynamics created some very interesting feedbacks to  $C_{fast}$  and  $C_{slow}$ .  
Both pools were found to be buffered against any changes in litter quantity with unchanged carbon  
stocks and a reduction to the MRTs (Table 3). In contrast, the chemical model MRT of both  $C_{fast}$   
430 and  $C_{slow}$  remained the same but with a significant change to their C stocks (Figure 3). We sug-  
gest the buffering of SOC was due to the introduction of microbial activity, which accelerated the  
turnover of new C introduced by litter, increased respiration rapidly (Figure 4) and consumed the  
rest for microbial biomass growth (Table 3d) keeping  $C_{slow}$  and  $C_{fast}$  unchanged. Further model  
experiments are required to investigate the effect of seasonal cycles in litter inputs.

435 Comparing the sensitivity of the biological and chemical model we found that introducing mi-  
crobial activity removed the sensitivity of  $C_{fast}$  and  $C_{slow}$  to litter inputs (Figure 2) but introduced  
significant sensitivity to parameters related to either growth or death of microbial biomass. The  
buffering of SOC in the biological model is once again apparent as microbial priming will rapidly  
consume carbon coming from litter inputs, and thus leave the soil pools unaffected. We found how-  
440 ever that  $C_{microbes}$  was quite sensitive to litter input and in particular to foliage litter because it is the

biggest influx of carbon and foliage has the highest decomposition rate (Table 1). Further numerical experiments are necessary to explore the impact of the decomposition rates on microbial priming.  $C_{microbes}$  was found also to be highly sensitive to the fraction of lignin, a parameter related to litter quality. In the biological model the carbon consumed by microbes comes from the labile  $C_{fast}$  pool  
445 and thus has a preference for litter with low lignin content. Higher concentrations of lignin in litter will reduce or remove microbial priming. For our study,  $f_{lignin}$  was calibrated and chosen to be similar for each litter type, to ensure a steady state condition and simplify the analysis, resulting in a value larger than expected from literature (Chapin et al., 1986), which may have enhanced the impact of microbial priming. Also different plants in Arctic ecosystems were found to have differ-  
450 ent seasonal patterns of lignin concentration in their foliage, stem and roots (Chapin et al., 1986). For example Chapin et al. (1986) found that the fraction of lignin for birch in the Alaskan tundra was between 0.05 to 0.15 for leaves from July to August and 0.25 to 0.18 for roots for the same period. Seasonal variability of lignin is likely to affect the timing of microbial priming. Further numerical experiments are needed to explore further the impact of different lignin fraction of differ-  
455 ent vegetation parts (i.e., foliage, root and wood) and with seasonal variation, closely linked to field data.

#### **4.2 H2. Warming will stimulate decomposition in the chemical model, and loss of SOC, but the SOC in the biological model will be less sensitive to warming due to complex interactions between SOC and the microbial pool.**

460 Our results (Figure 6) support the hypothesis. The first order representation of temperature on the chemical model kinetics caused a loss of SOC with warming. In the biological model SOC was buffered from climate change by microbial dynamics. For the biological model we assumed microbial activity were directly affected by temperature (Equation 7) and thus processes that are linked to microbial activity are indirectly affected by temperature.

465 Microbial death is also related to first order kinetics with temperature (Equation 11). Warming increased microbial death, reducing microbial biomass and thus reducing microbial activity making decomposition less sensitive to temperature. These indirect and compensating effects on microbial activity and biomass explain why SOC appears is less sensitive to temperature effects in the biological model.

470 There is recent evidence that temperature change will effect the efficiency with which carbon is converted to microbial biomass (Melillo et al., 2002; Allison et al., 2010; Wetterstedt and Ågren, 2011; Frey et al., 2013). Allison et al. (2010) found the response of soil carbon to climate depends on the efficiency of microbial biomass in using carbon, linking the resilience in both soil respiration and soil carbon with warming to a decline in microbial biomass and degradation of enzymes. We  
475 also found the biological model produced a drop in soil respiration after an increase of 5% the first year of warming (data not shown), returning to its original steady state value after 20 years (Figure

4b). Allison et al. (2010) suggests that enzymic acclimation will produce less respiration the first years of warming and the drop will be smoother. This is a process which is currently missing from our model but if included could possibly make it even less sensitive to temperature.

480 For any further development to include enzymic acclimation, the model will have also to consider the impact of litter quality on microbial efficiency. Frey et al. (2013) showed microbial efficiency dependency on both temperature and quality of the substrate decomposed, with microbial efficiency dropping for more refractory material under warm conditions. They found temperature had insignificantly affected microbial efficiency of glucose decomposition, attributing this to glucose not requiring extracellular enzymatic breakdown. They also showed microbial efficiencies had a narrow range  
485 between 70% and 75%. We calculated microbial efficiency for our biological model as the ratio of the total flux between  $C_{fast}$  and  $C_{microbes}$  minus growth respiration to the total flux between the two pools. We found that efficiency remained unchanged at 63% with either increase or decrease of temperature. Wetterstedt and Ågren (2011) have used a microbial decomposition related to temper-  
490 ature in a modelling study, but they also included a dependency on litter quality. In an incubation experiment, they used two different litter qualities with different lability and found that the higher quality litter had a greater contribution to soil respiration than the lower quality. Including both temperature and difference in litter quality, their model showed greater sensitivity in respiration rates and SOC dynamics. In our model, we considered only temperature effects (Equation 7). The lack  
495 of any direct impact of litter quality on microbial activity might have significantly reduced the sensitivity of temperature on decomposition since. Further development of the biological model should consider including decomposition of other substrates and making microbial activity dependent on both temperature and litter quality.

The biological model was also able to replicate the findings by Luo et al. (2001) who showed  
500 soil respiration acclimatized to temperature, that is, temperature sensitivity of soil respiration was reduced when exposed to warming. They suggest acclimatization occurred because of changes to the microbial community which reduced the respiratory capacity of the soil. We found the increase in microbial biomass with warming (Figure 6g) corresponded with the increase in soil respiration. Respiration initially increased due to increased microbial biomass which boosted decomposition.  
505 As microbial biomass increased, reduction in fast carbon due to consumption, combined with a high microbial death because of high microbial biomass, inhibited the growth of microbes reducing decomposition and respiratory losses. The initial change to microbial biomass was eventually eradicated, returning to its initial steady state and returning respiration back to its original value, removing any further sensitivity of temperature on respiration.

510 Melillo et al. (2002) also found that soil warming accelerated decomposition of soil organic matter and increased soil respiration but only for a short period of a few years. They attributed these dynamics to a reduction of the size of labile soil carbon pool. The biological model was able to replicate the observation by Melillo et al. (2002) (Figure 6e). The stimulation by temperature of

microbial activity increased microbial biomass, increased carbon consumption and reduced labile  
515 carbon which then inhibited further microbial growth. The fact that the biological model responded  
similarly to many observed processes found by a number of studies (Melillo et al., 2002; Allison  
et al., 2010; Wetterstedt and Ågren, 2011; Frey et al., 2013) in response to temperature gives us  
greater confidence that the biological model was able to capture those key process responses than  
the chemical model. The magnitude of the responses of respiration in the biological model were  
520 somehow lower than expected, with only 5% to 6% to that of 40% of Allison et al. (2010), but the  
Arctic climate drivers for the model make comparison with the temperate location of the field ex-  
periments less straightforward. The uncertainty of some of the parameters as well as the uncertainty  
of the parameterisation process itself might have been the reason for the low response and further  
testing with assimilation of observational data is required to increase the confidence of the model  
525 outputs.

On the other hand, the chemical model showed very different response to the observations by  
Melillo et al. (2002) with the labile carbon actually growing with warming. In general, the model  
showed a rapid response to temperature change due to a direct link of decomposition with temper-  
ature. The rate at which C stocks responded to climate change was higher for  $C_{fast}$  than  $C_{slow}$ .  
530 We found that soil respiration of the chemical model increased in the first year by ~6% (data not  
shown) but had not reached its original steady state value at the end of the 1000 year simulation.  
The chemical model was not able to show the fast drop in respiration because C stocks continued to  
change and reached a steady much later than in the biological model. This chemical response did  
not allow respiration to recover to its steady state value thus not reproducing any of the responses  
535 found by Luo et al. (2001), Melillo et al. (2002) or Allison et al. (2010).

The acclimatization of soil respiration, the buffering of C stocks and the high sensitivity of SOC  
decomposition to the quality of the litter were the three major differences highlighted by our direct  
comparison between the biological and chemical model. The two models were kept as similar as  
possible and only differed in the way microbial activity was incorporated into decomposition pro-  
540 cesses, and, critically, the activity of the fast labile pool. In the biological model,  $C_{fast}$  was nothing  
more than a pathway of carbon between litter and microbial community. This made a pool with very  
fast turnover rates. In contrast,  $C_{fast}$  in the chemical model is another pool like  $C_{slow}$ , but with  
the difference of a faster decomposition rate. To understand the results of our study it is important  
to separate the conceptual difference of the fast pool between the two models. The differences we  
545 observed between the two models were because of this difference in the concept of carbon flow from  
litter to soil and how microbial influence was introduced through the concept of microbial activity.

Using such an alternative model, which introduces buffering of SOC to litter quantity and tem-  
perature and a sensitivity to litter quality, can give us a different understanding on the sensitivity of  
Arctic C stocks to global change.



## 550 5 Conclusions

Microbial activity, and its related priming, is a process absent from most models of soil organ carbon decomposition (Jenkinson and Rayner, 1977; Parton et al., 1988; Li et al., 1992; Metherell et al., 1993; Coleman et al., 1997; Li et al., 1997; Smith et al., 2007, 2010). While priming has largely been studied in short-term incubation studies Blagodatsky et al. (1998, 2010, 2011) field research  
555 has recently highlighted its importance also in Arctic ecosystems (Allison et al., 2010; Schmidt et al., 2011; Hartley et al., 2012; Frey et al., 2013). The modelling challenge is to extend the short term understanding from incubation to long term responses, to underpin studies on the impact of warming, and linked vegetation changes, on existing soil C stocks of the high latitudes.

The standard chemical model showed more significant long-term responses of SOC to changes in  
560 climate and litter inputs, whereas in the biological model microbial processes rapidly responded, to buffer C stocks against change these changes. Microbial processes adjusted at a finer temporal scale with rapid microbial turnover stabilising the main C stocks. In contrast the chemical model was slow to respond, but ultimately was much more responsive to forcing over the longer-term.

The advantages of using a biological model is that it allows the investigation of complex inter-  
565 actions between microbes, litter quality, quantity and temperature. These complex interactions are likely to be more important when vertical variability of the soil profile is introduced (Schmidt et al., 2011). Further development of the model should include such variability by allowing processes to vary with depth and introduce physical variation in temperature and biophysical processes such as diffusion of oxygen and carbon dioxide, which will affect decomposition and soil respiration.

570 Our study suggests that the use of a chemical model is a simplification of the reality which does not match experimental warming observations. Likewise, Wutzler and Reichstein (2008) have noted that representing active decomposers in a nonlinear manner, as in DecoBio, is most suitable for describing long-term SOC dynamics. The main conclusion of the study, is that by excluding the impact of microbial community we miss key processes that introduce complex, often stabilising  
575 feedbacks (Wieder et al., 2013).

## 6 Code availability

The FORTRAN 95 source code for both DecoChem v1.0 and DecoBio v1.0 presented in this paper are freely available either through the supplementary material or directly by contacting the authors. The code was compiled using GNU Fortran 4.6.3 compiler freely available to all Unix based oper-  
580 ating systems.

*Acknowledgements.* This work was funded by the NERC ARCC project. We thank two anonymous reviewers for their inputs, and J. Exbrayat for helpful comments.

## References

- Allison, S. D., Wallenstein, M. D., and Bradford, M. A.: Soil-carbon response to warming dependent on microbial physiology, *Nature Geoscience*, 3, 336–340, 2010.
- 585 Blagodatsky, S., Blagodatskaya, E., Yuyukina, T., and Kuzyakov, Y.: Model of apparent and real priming effects: Linking microbial activity with soil organic matter decomposition, *Soil Biology and Biochemistry*, 42, 1275–1283, 2010.
- Blagodatsky, S., Rüdiger, G., Kiese, R., Werner, C., and Butterbach-Bahl, K.: Modelling of microbial carbon and nitrogen turnover in soil with special emphasis on N-trace gases emission, *Plan Soil*, 346, 297–330, 2011.
- 590 Blagodatsky, S. A., Yevdokimov, I. V., Larionova, A. A., and Richter, J.: Microbial growth in soil and nitrogen turnover: Model calibration with laboratory data, *Soil Biology and Biochemistry*, 13, 1757–1764, 1998.
- Chapin, F., McKendrick, J., and Johnson, D.: Seasonal changes in carbon fractions in Alaskan tundra plants of differing growth form: implications for herbivory, *Journal of Ecology*, 74, 707–731, 1986.
- 595 Coleman, K., Jenkinson, D., Crocker, G., Grace, P., Klír, J., Körchens, M., Poulton, P., and Richter, D.: Simulating trends in soil organic carbon in long-term experiments using RothC-26.3, *Geoderma*, 81, 29–44, 1997.
- Fenner, N. and Freeman, C.: Drought-induced carbon loss in peatlands, *Nature Geoscience*, 4, 895–900, 2011.
- 600 Frey, S. D., Lee, J., Melillo, J. M., and Six, J.: The temperature response of soil microbial efficiency and its feedback to climate, *Nature Climate Change*, 3, 395–398, 2013.
- Hartley, I. P., Garnett, M. H., Sommerkorn, M., Hopkins, D. W., Fletcher, B. J., Sloan, V. L., Phoenix, G. K., and Wookey, P. A.: A potential loss of carbon associated with great plant growth in the European Arctic, *Nature Climate Change*, 2, 875–879, 2012.
- 605 Ise, T., Dunn, A. L., Wofsy, S. C., and Moorcroft, P. R.: High sensitivity of peat decomposition to climate change through water-table feedback, *Nature Geoscience*, 1, 763–766, 2008.
- Jenkinson, D. and Rayner, J.: The turnover of soil organic matter in some of the Rothamsted classical experiments, *Soil Science*, 123, 298–305, 1977.
- Jorgenson, T., Romanovsky, V., Jarden, J., Shur, Y., O'Donnel, J., Schuur, E., Kanavskiy, M., and Marchenko, S.: Resilience and vulnerability of permafrost to climate change, *Canadian Journal of Forest Research*, 40, 1219–1236, 2010.
- 610 Koven, C., Ringeval, B., Friedlingstein, P. Ciais, P., Cadule, P., Khvorostyanov, D., Krinner, G., and Tamocai, C.: Permafrost carbon-climate feedbacks accelerate global warming, *Proceedings of the National Academy of Sciences*, 108, 14769–14774, 2011.
- 615 Li, C., Frolking, S., and Frolking, T.: A model of nitrous oxide evolution from soil driven by rainfall events: 1. Model structure and sensitivity, *Journal of Geophysical Research*, 97, 9759–9776, 1992.
- Li, C., Frolking, S., Crocker, G., Grace, P., Klír, J., Körchens, M., and Poulton, P.: Simulating trends in soil organic carbon in long-term experiments using the DNDC model, *Geoderma*, 81, 45–60, 1997.
- Liski, J., Palosuo, T., Peltoniemi, M., and Sievänen: Carbon and decomposition model Yasso for forest soils, *Ecological Modelling*, 189, 168–182, 2005.
- 620 Luo, Y., Wan, S., Hui, D., and Wallace, L.: Acclimatization of soil respiration to warming in a tall grass prairie, *Nature*, 413, 622–625, 2001.

- Mahecha, M. D., Reichstein, M., Carvalhais, N., Lasslope, G., Lange, H., Seneviratne, S. I., Vargas, R., Ammann, C., Altaf Arrain, M., Cescatti, A., Janssens, I. A. Migliavacca, M., Montagnani, L., and Richardson, A. D.: Global convergence in the temperature sensitivity of respiration at ecosystem level, *Science*, 329, 838–840, 2010.
- 625 McGuire, D., Anderson, L., Christensen, T., Dallimore, S., Guo, L., Hayes, D., Heimann, M., Lorensen, T., MacDonald, R., and Roulet, N.: Sensitivity of the carbon cycle in the Arctic to climate change, *Ecological Monographs*, 79, 523–555, 2009.
- 630 Melillo, J. M., Steudler, P. A., Aber, J. D., Newkirk, K., Lux, H., Bowles, F. P., Catricala, C., Magill, A., Ahrens, T., and Morrisseau, S.: Soil warming and carbon-cycle feedbacks to the climate system, *Science*, 298, 2173–2176, 2002.
- Metherell, A., Harding, L., Cole, C., and Parton, W.: CENTURY soil organic matter model environment. Technical documentation. Agroecosystem version .0, Tech. rep., Great Plains System Research Unit, 1993.
- 635 Panikov, N. S.: *Microbial growth kinetics*, Springer, 1995.
- Parton, W., Stewart, J., and Cole, C.: Dynamics of C, N, P and S in grassland soils: a model., *Biogeochemistry*, 5, 109–131, 1988.
- Rogers, M., Sullivan, P., and Welker, J.: Evidence of nonlinearity in the response of net ecosystem  $CO_2$  exchange to increasing levels of winter snow depth in the high Arctic of Northwest Greenland, *Arctic, Antarctic, and Alpine Research*, 43, 95–106, 2011.
- 640 Sanderson, M., Hemming, D., and Betts, R.: Regional temperature and precipitation changes under high-end ( $\geq 4^\circ C$ ) global warming, *Philosophical Transactions of the Royal Society*, 369, 85–98, 2011.
- Schädel, C., Luo, Y., Evans, D. R., Fei, S., and Schaeffer, S. M.: Separating soil  $CO_2$  efflux into C-pool-specific decay rates via inverse analysis of soil incubation data, *Oecologia*, 171, 721–732, 2013.
- 645 Schmidt, M., Torn, M., Abiven, S., Dittmar, T., Guggenberger, G., Janssens, I., Kleber, M., Kögel-Knabner, I., Lehmann, J., Manning, D., Nannipieri, P., Rasse, D. P., Weiner, S., and Trumbore, E.: Persistence of soil organic matter as an ecosystem property, *Nature*, 478, 49–56, 2011.
- Sloan, V. L., Benjamin, J. F., Press, M. C., Williams, M., and Phoenix, G. K.: Leaf and root carbon stocks and turnover are coupled across multiple Arctic ecosystems, *Global Change Biology*, 19, 3668–3676, 2013.
- 650 Smith, J., Gottschalk, P., Bellarby, J., Chapman, S., Lilly, A., Towers, W., Bell, J., Coleman, K., Nayak, D., Richards, M., Hillier, J., Flynn, H., Wattenbach, M., Aitkenhead, M., Yeluripati, J., Farmer, J., Milne, R., Thomson, M., Evans, C., Whitmore, A., Falloon, P., and Smith, P.: Estimating changes in Scottish soil carbon stocks using ECOSSE. I. Model description and uncertainties, *Climate research*, 45, 179–192, 2010.
- Smith, P., Smith, J., Flynn, H., Killham, K., Rangel-Castro, I., Foereid, B., Aitkenhead, M., Chapman, S., Towers, W., Bell, J., Lumsdon, D., Milne, R., Thomson, A., Simmons, I., Skiba, U., Reynolds, B., Evans, C., Frogbrook, Z., Bradley, I., Whitmore, A., and Falloon, P.: ECOSSE: Estimating carbon in organic soils - Sequestration and emissions. Final Report., Tech. rep., Scottish Executive, 2007.
- 655 Street, L. E., Subke, J. A., Sommerkom, M., Sloan, V., Ducrottoy, H., Phoenix, G. K., and Williams, M.: The role of mosses in carbon uptake and partitioning in arctic vegetation, *New Phytologist*, 199, 163–175, 2013.
- 660 Tarnocai, C., Canadell, J., Schuur, E., Kuhry, P., and Mazhitova, G.: Soil organic carbon pools in the northern circumpolar permafrost region, *Global Biogeochemical Cycles*, 23, GB2023, 2009.
- Turetsky, M. R., Crow, S. E., Evans, R. J., Vitt, D. H., and Weider, K. R.: Trade-offs in resource allocation

- among moss species control decomposition in boreal peatlands, *Journal of Ecology*, 96, 1297–1305, 2008.
- 665 Wetterstedt, J. A. M. and Ågren, G. I.: Quality or decomposer efficiency - Which is most important in the temperature response of litter decomposition? A modeling study using the GLUE methodology., *Biogeochemistry*, 8, 477–487, 2011.
- Wieder, W. R., Bonan, G. B., and Allison, S. D.: Global soil carbon projections are improved by modelling microbial processes, *Nature*, 3, 909–912, 2013.
- 670 Wissler, D., Marchenko, S., Talbot, J., Treat, C., and Frohking, S.: Soil temperature response to 21st century global warming: the role of and some implications for peat carbon in thawing permafrost soils in North America., *Earth System Dynamics*, 2, 121–138, 2011.
- Wutzler, T. and Reichstein, M.: Colimitation of decomposition by substrate and decomposers; a comparison of model formulations, *Biogeosciences*, 5, 749–759, 2008.
- 675 Xenakis, G., Ray, D., and Mencuccini, M.: Sensitivity and uncertainty analysis from a coupled 3-PG and soil organic matter decomposition model, *Ecological Modelling*, 219, 1–16, 2008.